



## Ecodesign Preparatory Studies

### Lot 21: Central heating products using hot air to distribute heat (other than CHP)

**1<sup>st</sup> Stakeholder Meeting  
Brussels– April 19<sup>th</sup> 2011**

---

*A study being conducted for DG ENER by BIO Intelligence Service  
and TÜV Rheinland*



10:00 – 10:15	Welcome, “Tour de table” (EC)
10:15 – 10:25	Introduction to the Ecodesign Directive (BIO)
10:25 – 10:40	Interaction with other Ecodesign lots (BIO)
	Task 1 - Definition: Presentation and discussion of product categories, existing standards and legislation (BIO/TÜV)
	COFFEE BREAK
	Discussion on scope and findings
13:00 – 14:00	LUNCH BREAK
	Task 2 – Economic and market analysis: Presentation and discussion (BIO)
	Task 3 – Consumer behaviour and local infrastructure: Presentation and discussion (BIO/TÜV)
	COFFEE BREAK
16:00 – 16:30	Next steps – Tasks 4, 5 and 6 (BIO)
	Discussion on base cases (BIO/TÜV)
16:30 – 17:00	Conclusion and wrap up (EC)

10:00 – 10:15	Welcome, “Tour de table” (EC)
10:15 – 10:25	Introduction to the Ecodesign Directive (BIO)
10:25 – 10:40	Interaction with other Ecodesign lots (BIO)
	Task 1 - Definition: Presentation and discussion of product categories, existing standards and legislation (BIO/TÜV)
	COFFEE BREAK
	Discussion on scope and findings
13:00 – 14:00	LUNCH BREAK
	Task 2 – Economic and market analysis: Presentation and discussion (BIO)
	Task 3 – Consumer behaviour and local infrastructure: Presentation and discussion (BIO/TÜV)
	COFFEE BREAK
16:00 – 16:30	Next steps – Tasks 4, 5 and 6 (BIO)
	Discussion on base cases (BIO/TÜV)
16:30 – 17:00	Conclusion and wrap up (EC)

## Commission Policy Officer:

- Guido de Wilt (DG ENER)

## BIO Intelligence Service:

- (Shailendra Mudgal)
- Benoît Tinetti
- Adrian Tan
- Sandeep Pahal
- Alvaro de Prado Trigo

## TÜV Rheinland:

- (Frank Gossen)
- Friedrich Rick
- Thomas Stueber
- Jens Helpenstell

*Pioneer in quantification tools and support for decision-making*

- Specialists in the measurement environmental and health quality of products and services in France and Europe
- At the interface of the environment and products, a large range of services for public and private decisions makers

- Life cycle assessment
- Environmental labelling of products
- Eco-design of products
- Greening the supply chain
- Assessment of public policies



- Energy
- Agri-food
- Construction
- Retail
- Industry
- Transport
- Waste
- Services



# BIO's activities

Since 1989, our references include:

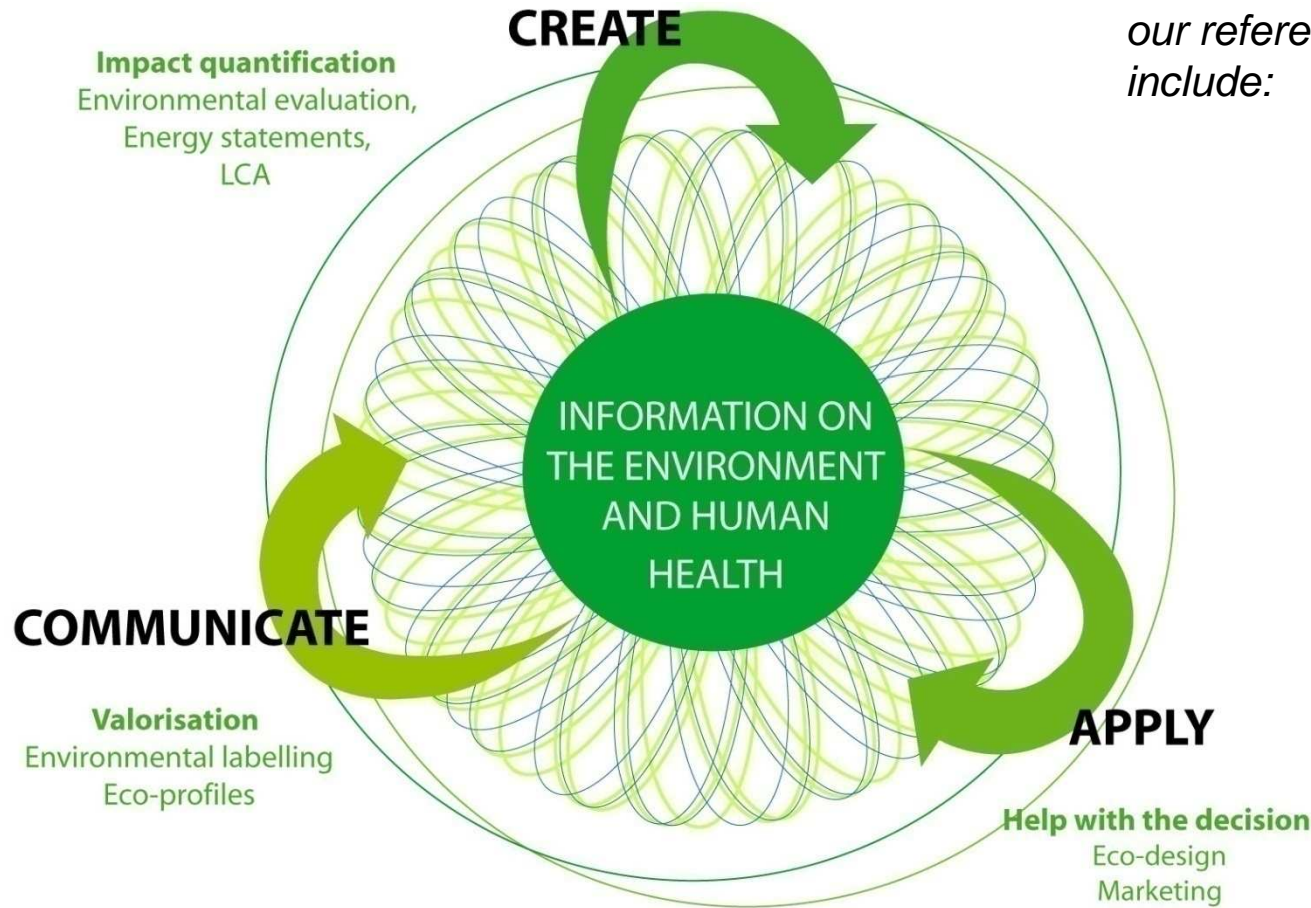

## **TÜV Rheinland Energie und Umwelt GmbH,** Test Centre for Energy Technologies

- Expertise in conformity assessments of heating appliances, safety analysis and performance tests of energy appliances
- Main tasks involved in:
  - Test standards
  - Technical analysis of products

10:00 – 10:15	Welcome, “Tour de table” (EC)
<b>10:15 – 10:25</b>	<b>Introduction to the Ecodesign Directive (BIO)</b>
10:25 – 10:40	Interaction with other Ecodesign lots (BIO)
	Task 1 - Definition: Presentation and discussion of product categories, existing standards and legislation (BIO/TÜV)
	COFFEE BREAK
	Discussion on scope and findings
13:00 – 14:00	LUNCH BREAK
	Task 2 – Economic and market analysis: Presentation and discussion (BIO)
	Task 3 – Consumer behaviour and local infrastructure: Presentation and discussion (BIO/TÜV)
	COFFEE BREAK
16:00 – 16:30	Next steps – Tasks 4, 5 and 6 (BIO)
	Discussion on base cases (BIO/TÜV)
16:30 – 17:00	Conclusion and wrap up (EC)

Directive 2009/125/EC of the European Parliament, **Framework Directive** for the setting of ecodesign requirements for **Energy-related Products (ErP)**

- Promotion of sustainable development through free movement of energy using products, environmental protection and increased security of energy supply
- Better regulation: efficient decision making, consultation and self regulation

*“Energy-related product means any good that has an impact on energy consumption during use which is placed on the market and/or put into service”*

This Directive supersedes the former EuP Directive (2005/32/EC) which covered only Energy-using Products.

## Scope of the Directive:

- All Energy-related Products (except transport)
- Specific **product categories** for ecodesign requirements

## Measures of action:

- Setting of ecodesign requirements (**Implementing Measures**)

## Implementing Measures

- could be proposed for product categories which:
  - represent a significant volume of products placed on the EU market (> 200.000 units/year),
  - involve a significant environmental impact, and
  - present a significant potential for improvement
- are to be based on
  - environmental assessments / relevant product characteristics and functionality
  - products and technologies available on the market should be taken as reference
- IM should preserve the interests of industry, consumers and other stakeholders

# From a Preparatory Study to Implementing Measures

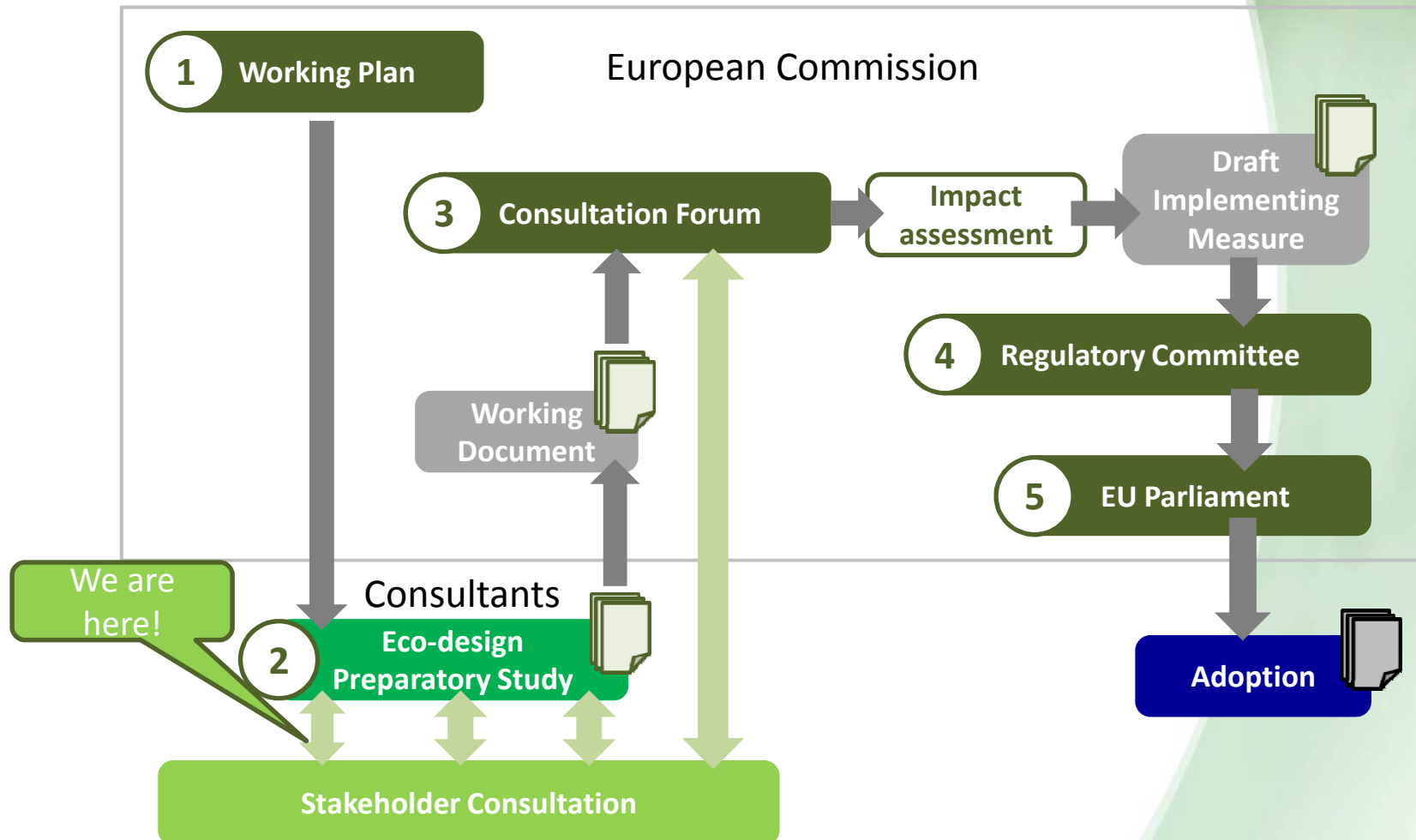

### 2006: 14 lots DG ENER (completed)

- lot 1 boilers and combi-boilers
- lot 2 water heaters
- lot 3 personal computers
- lot 4 imaging equipment
- lot 5 consumer electronics (TV) \*
- lot 6 standby and off-mode losses \*
- lot 7 battery chargers and external power supplies \*
- lot 8 office lighting \*
- lot 9 (public) street lighting \*
- lot 10 residential room conditioning appliances
- lot 11 electric motors 1-150 kW, pumps, circulators, fans \*
- lot 12 commercial refrigerators and freezers
- lot 13 domestic refrigerators and freezers \*
- lot 14 domestic dishwashers and washing machines

### 2008: 3 lots DG ENTR

- lot 1 commercial refrigerators and freezers
- lot 2 transformers (power and distribution)
- lot 3 DVD players, video projectors, etc.

### 2007: 5+1 lots DG ENER (completed)

- lot 15 solid fuel small combustion installations
- lot 16 laundry dryers
- lot 17 vacuum cleaners
- lot 18 complex set-top boxes
- lot 19 domestic lighting \*
- + simple set-top boxes \*

### 2008: 8 lots DG ENER

- lot 20 individual room heating
- lot 21 central heating (hot air)
- lot 22 ovens
- lot 23 hobs and grills
- lot 24 washing machines, etc. PRO
- lot 25 coffee machines
- lot 26 network standby

### 2009: 3 lots DG ENTR

- lot 4 industrial furnaces and ovens
- lot 5 machine tools
- lot 6 air-co and ventilation systems

- A uniform approach adopted for all the lots, Methodology for Eco-design of Energy-using Products - MEEuP:

Tasks 1 to 5	Present situation
Tasks 6 to 8	Improvement potential

1<sup>st</sup> Stakeholder meeting

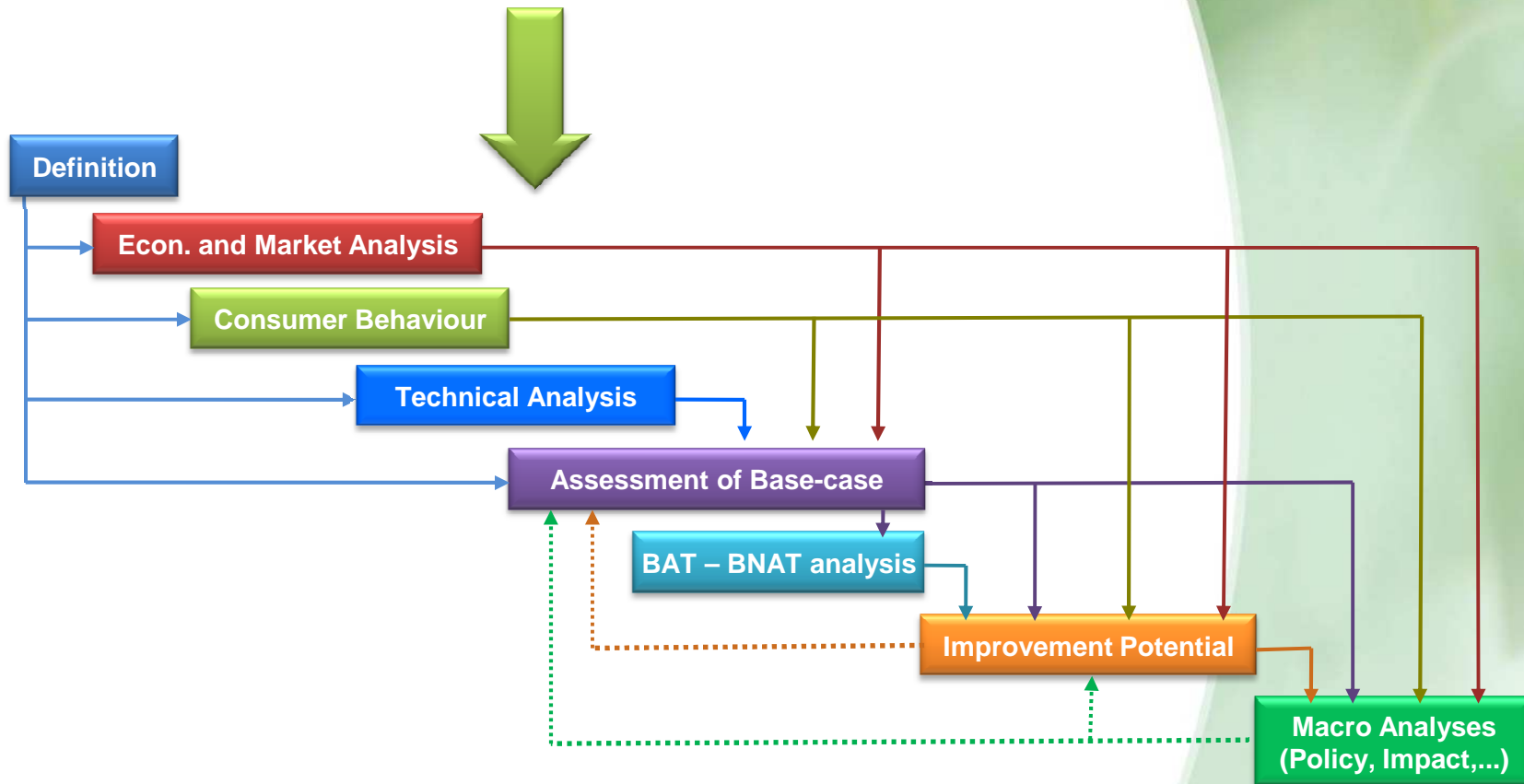

- Task 1
- Task 2
- Task 3
- Task 4
- Task 5
- Task 6
- Task 7
- Task 8

10:00 – 10:15	Welcome, “Tour de table” (EC)
10:15 – 10:25	Introduction to the Ecodesign Directive (BIO)
10:25 – 10:40	<b>Interaction with other Ecodesign lots (BIO)</b>
	Task 1 - Definition: Presentation and discussion of product categories, existing standards and legislation (BIO/TÜV)
	COFFEE BREAK
	Discussion on scope and findings
13:00 – 14:00	LUNCH BREAK
	Task 2 – Economic and market analysis: Presentation and discussion (BIO)
	Task 3 – Consumer behaviour and local infrastructure: Presentation and discussion (BIO/TÜV)
	COFFEE BREAK
16:00 – 16:30	Next steps – Tasks 4, 5 and 6 (BIO)
	Discussion on base cases (BIO/TÜV)
16:30 – 17:00	Conclusion and wrap up (EC)

Space Heating: related lots

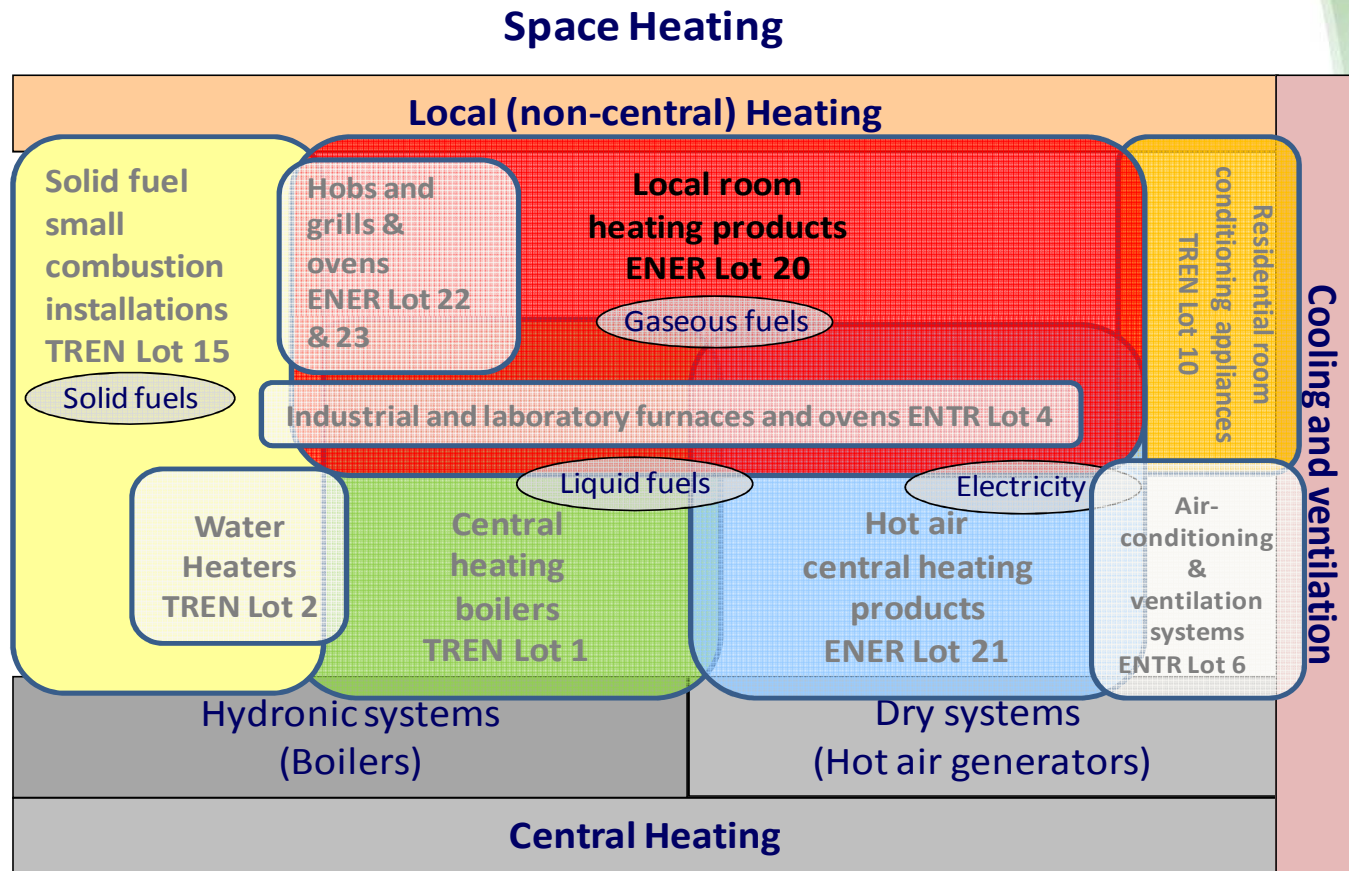

## Striving for coherency and consistency in HVAC Ecodesign preparatory studies

- Performance of products will be analysed from a system perspective similar to the approach taken in other EuP studies
- The approach will also strive to be consistent with EPBD
- Only after the technical analysis of the products, will a decision be made on whether implementing measures will focus on individual products or systems

10:00 – 10:15	Welcome, “Tour de table” (EC)
10:15 – 10:25	Introduction to the Ecodesign Directive (BIO)
10:25 – 10:40	Interaction with other Ecodesign lots (BIO)
	<b>Task 1 - Definition: Presentation and discussion of product categories, existing standards and legislation (BIO/TÜV)</b>
	COFFEE BREAK
	Discussion on scope and findings
13:00 – 14:00	LUNCH BREAK
	Task 2 – Economic and market analysis: Presentation and discussion (BIO)
	Task 3 – Consumer behaviour and local infrastructure: Presentation and discussion (BIO/TÜV)
	COFFEE BREAK
16:00 – 16:30	Next steps – Tasks 4, 5 and 6 (BIO)
	Discussion on base cases (BIO/TÜV)
16:30 – 17:00	Conclusion and wrap up (EC)

## Task 1 - Definition:

- Define the product category and define the system boundaries of the 'playing field' for eco-design
- Identify the harmonised test standards and additional sector-specific procedures for product-testing
- Identify the existing relevant legislation, voluntary agreements, and labelling initiatives at the EU and MS level, as well as outside Europe

1.1 Product category and performance assessment

1.2 Test Standards

1.3 Existing legislation (including labelling and voluntary programs)

## 1.1. Product Definition

Central heating products using hot air to distribute heat are products that generate heat by using burners, heat pumps or electricity and distribute the heat into remote spaces by means of hot air.

### ■ Heat sources

- Electricity
- Gas (natural gas, propane, LPG)
- Liquid fuel (kerosene, ethanol etc.)

### ■ Application

- Residential buildings
- Non-residential buildings (commercial and industrial)

# 1.1. Product Definition

- PRODCOM classification

PRODCOM code	PRODCOM Category
27.51.26.90	Other electric space heaters
27.52.12.33	Iron or steel gas domestic appliances with an exhaust outlet (including heaters, grates, fires and braziers, for both gas and other fuels; excluding cooking appliances and plate warmers)
27.52.12.35	Iron/steel gas domestic appliances (including heaters, grates, fires and braziers, for both gas and other fuels radiators; excluding cooking appliances and plate warmers, those with an exhaust outlet)
28.21.11.30	Furnace burners for liquid fuel
28.21.11.50	Furnace burners for solid fuel or gas (including combination burners)
28.25.12.70	Air conditioning machines not containing a refrigeration unit; central station air handling units; vav boxes and terminals, constant volume units and fan coil units
28.25.13.80	Heat pumps other than air conditioning machines of HS 8415
27.52.13.00	Air heaters or hot air distributors n.e.c., of iron or steel, non-electric

## 1.1. Product Definition

- Direct-gas-fired furnaces

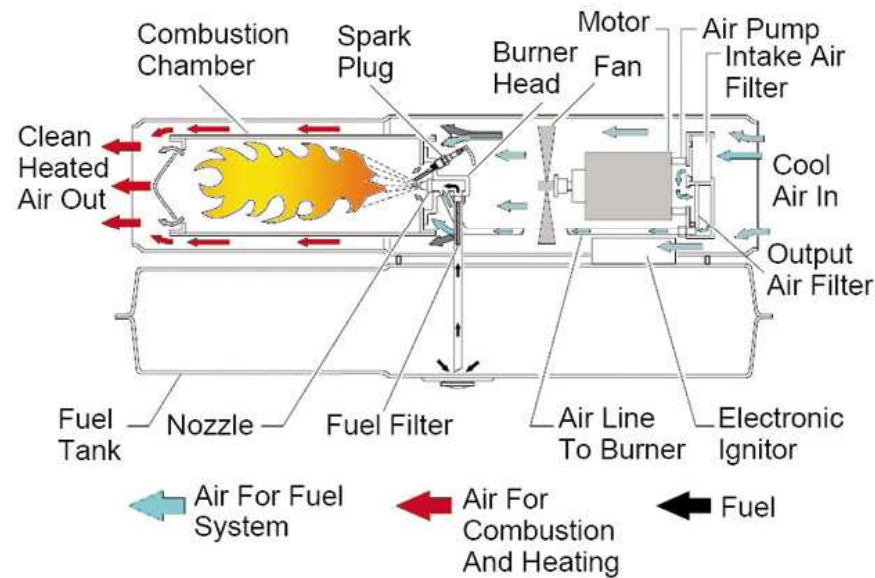

- The exhaust air of the furnace goes directly into the space heated
- Power ranges vary from 19 – 1,200 kW

## 1.1. Product Definition

- Indirect-gas-fired furnaces

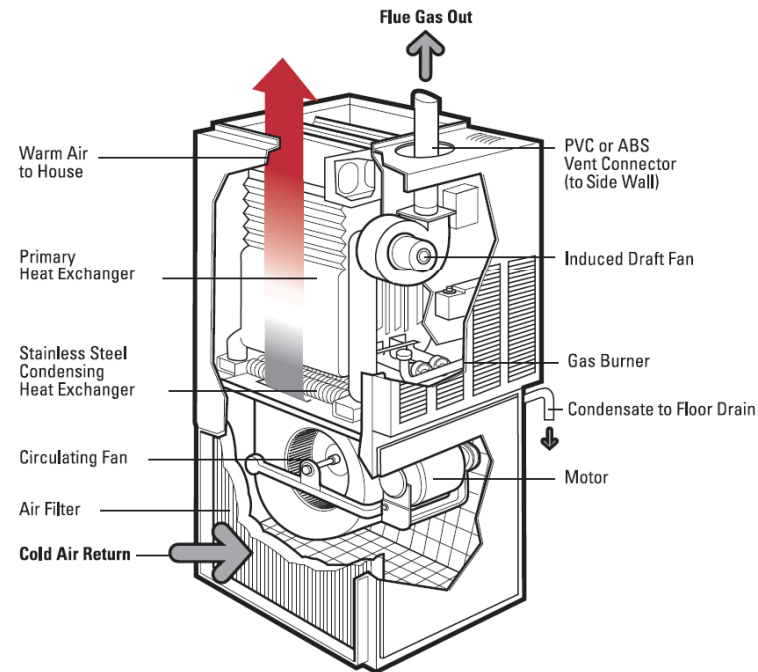

- Air going into the room is heated by the furnace through a heat exchanger
- Power ranges vary from 19 – 900 kW

## 1.1. Product Definition

- Liquid fuel-fired furnaces

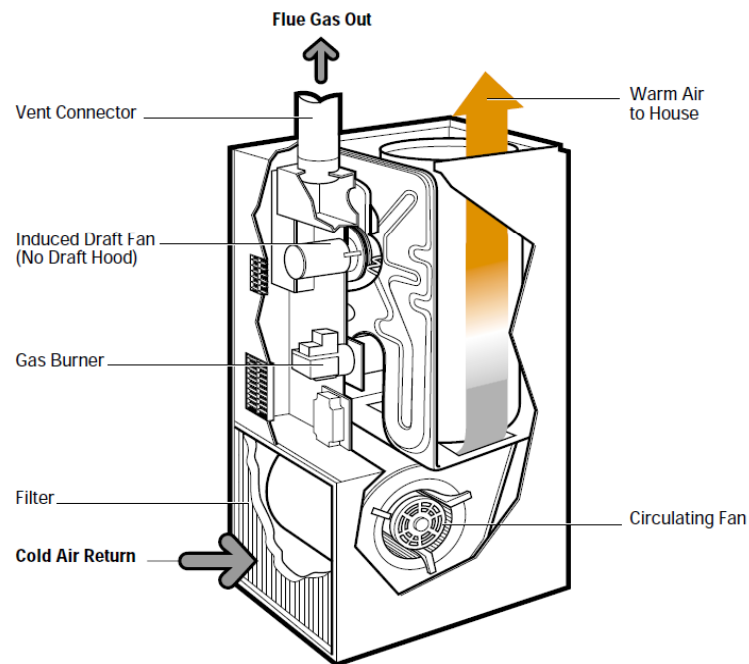

- Heat is transferred by a heat exchanger
- Power ranges vary from 35 – 400 kW

## 1.1. Product Definition

### ■ Electric furnaces

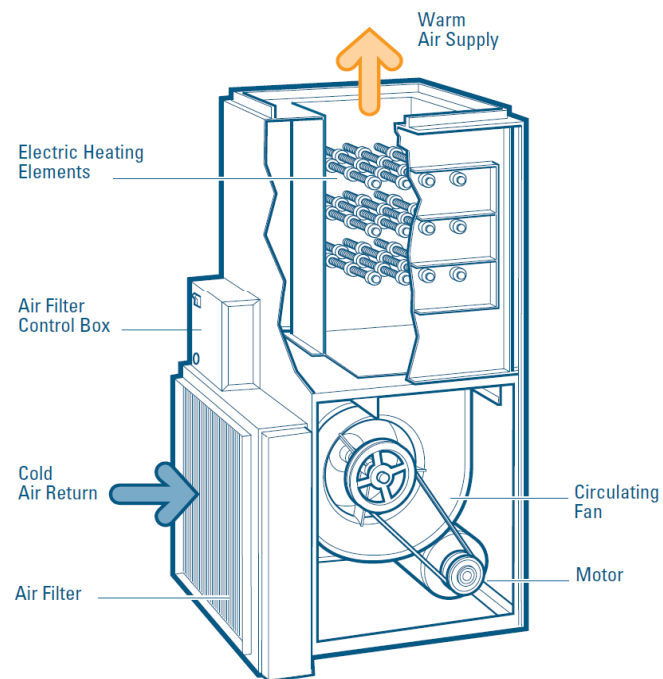

- Air is heated by an electric heating system
- Power ranges vary from 15 – 50 kW

## 1.1. Product Definition

- Multi-fuel-fired furnaces



- Coal, wood or liquid fuel-fired
- Power ranges vary from 50 – 500 kW

## 1.1. Product Definition

- Summary of furnaces

Type of central heating appliance	Energy source	Typical power output range (in kW)	Relevant standards
<b>Direct-gas-fired furnace</b>	Natural gas (NG) /propane/butane (LPG)	< 19 (r) 19 – 1,200 (c)	EN 525 EN 621 EN 676 EN 1020 EN 298
<b>Indirect-gas-fired furnace</b>	Natural gas (NG) /propane/butane (LPG)	< 19 (r) 19 – 900 (c)	EN 525 EN 621 EN 676 EN 1020 EN 298
<b>Liquid fuel-fired furnace</b>	Fuel oil/diesel/ kerosene	15 – 45 (r) 35 – 400 (c)	EN 267 EN 13842
<b>Electrical furnace</b>	Electricity	15 – 50	EN/IEC 60335-1
<b>Multi fuel-fired furnace</b>	Wood/coal and fuel oil	<50 (r) 50 - 500 (c)	TO BE COMPLETED

(r): residential, (c): commercial or industrial

## 1.1. Product Definition

- Air to air heat pumps

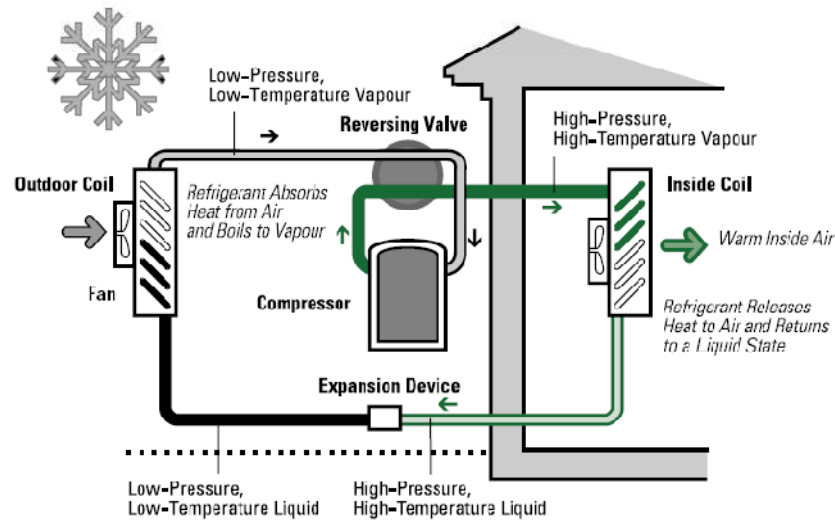

- Reversible air conditioners (provide heating and cooling)
- Typical power ranges are 19 – 65 kW
- Heat source: air
- Energy source: electricity, gas

## 1.1. Product Definition

- Ground to air heat pumps

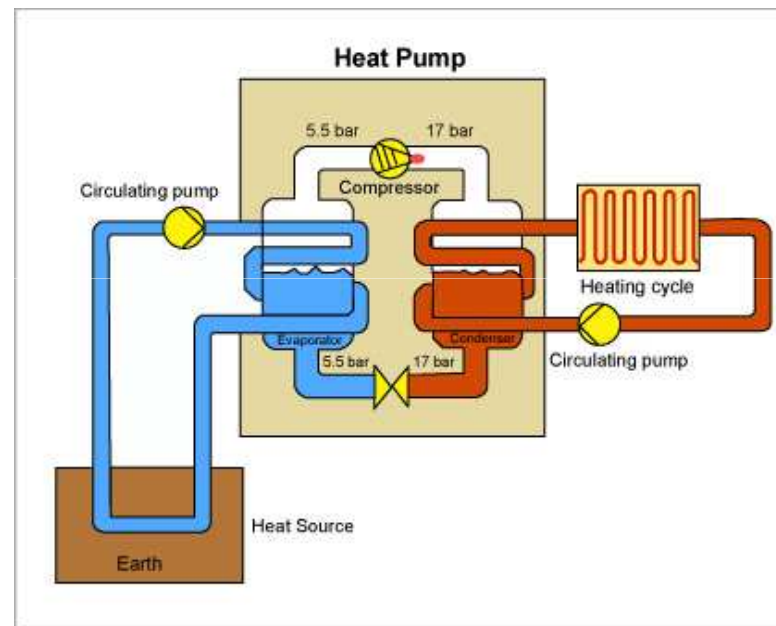

- Reversible air conditioners (provide heating and cooling)
- Typical power ranges are 19 – 65 kW
- Heat source: ground
- Energy source: electricity, gas

## 1.1. Product Definition

### ■ Water to air heat pumps

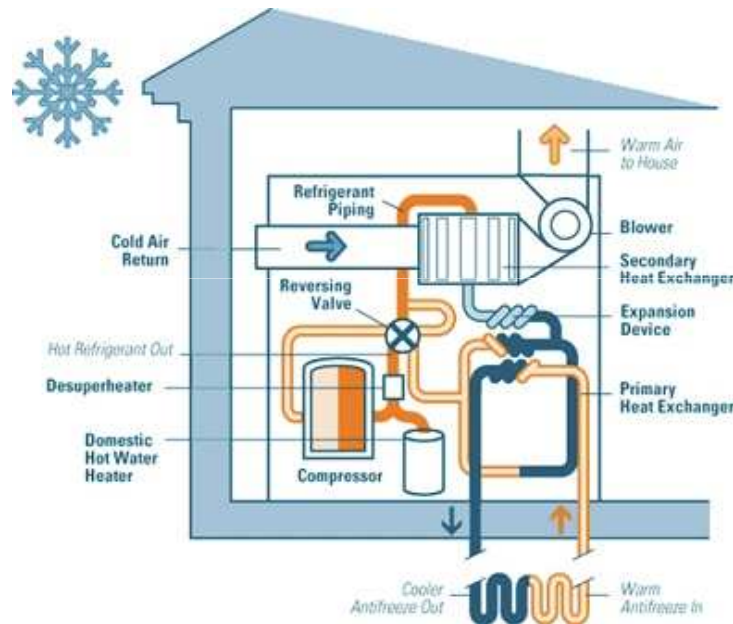

- Reversible air conditioners (provide heating and cooling)
- Typical power ranges are 19 – 65 kW
- Heat source: water
- Energy source: electricity, gas

## 1.1. Product Definition

- Summary of Heat pumps

Type of central heating appliance	Energy source	Typical power output range (in kW)	Relevant standards
Heat pump	Air/water/ ground	< 19 (r) 19 – 65 (c)	EN 225 EN 378 EN 14511

(r): residential, (c): commercial or industrial

## 1.1. Product Definition

### ■ Air handling units

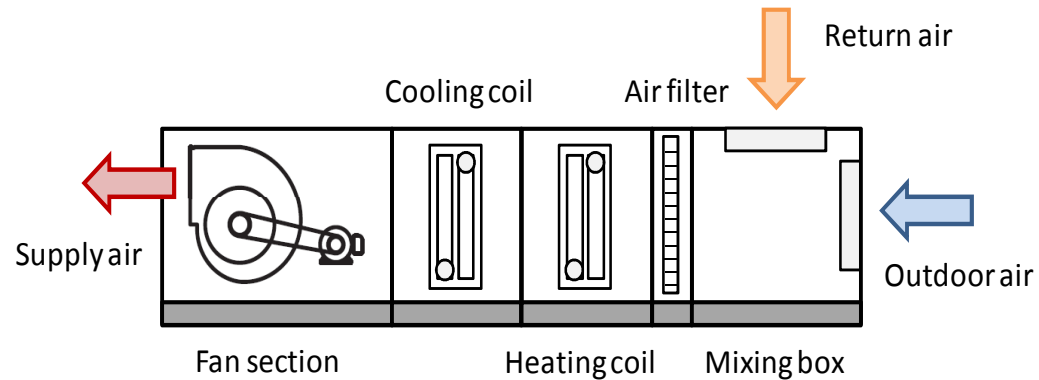

- Primary function is ventilation
- Typical power ranges are 20 – 1,200 kW

## 1.1. Product Definition

### ■ Rooftops



- Configuration of any product blowing hot/cold air
- No ductwork or short ductwork, not usually centralised system

## 1.1. Product Definition

- Fan coils

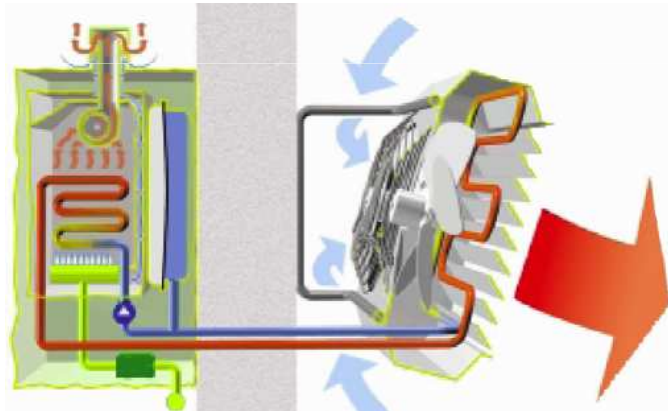

- Primary function is to blow air, which is heated or cooled by other machine

## 1.1. Product Definition

- Summary of Air handling units

Type of central heating appliance	Energy source	Typical power output range (in kW)	Relevant standards
Air handling unit (AHU)	Electricity/gas/oil	20 – 1,200 (c)	prEN 1886 prEN13053 EN 1020 EN 525

(r): residential, (c): commercial or industrial

## 1.1. Product Definition

- **Furnaces**

- Gas furnaces
- Liquid fuel furnaces
- Electric furnaces
- Multi-fuel furnaces (wood, coal or oil)

- **Heat pumps**

- Air to air
- Ground to air
- Water to air

---

- **Air handling units**

- **Rooftops**

- **Fan coils**

- **Air doors/curtains**

---

- **Combined Heat and Power**      Out of the scope

### Discussion of scope:



Rooftops?



Air handling units?



Fan coil units?



Air doors/curtains?



Agricultural applications?

## 1.1. Product Definition

### ■ Questions

- Any complementary items to mention in/out of the scope of the study?
- Are there any other parameters which should be considered for classification?
- Any comments?

### Standards in EU-27

➤ Performance standards

Document	Type of equipment	Title
EN 14511-2	Heat pumps	Air conditioners, liquid chilling packages and heat pumps with electrically driven compressors for space heating and cooling. Part 2: Test conditions
EN 267	Furnaces	Forced draught oil burners. Definitions, requirements, testing, marking
prEN 14825	Heat pumps	Air conditioners, liquid chilling packages and heat pumps, with electrically compressors, for space heating and cooling- Testing and rating at part load conditions and calculation of seasonal performance
DIN 4794	Furnaces	Stationary fan-assisted air heaters; gas fired air heaters without interchange of heat, safety requirements, testing
prEN 13053	AHU	Ventilation for buildings - Air handling units - Ratings and performance for units, components and sections
prEN 1886	AHU	Ventilation for buildings - Air handling units - Mechanical performance

## Standards in MS

### ➤ Performance standards

Member State	Standard	Title
<b>Denmark</b>	DS 2187	Oil burning, fan-assisted air heaters
<b>Germany</b>	DIN V 4701-10	Energy efficiency of heating and ventilation systems in buildings Part 10: Heating, domestic hot water, ventilation
	DIN 33830	Heat pumps, complete absorption pump units, concepts requirements, testing, marking
	DVGW VP 120	Gas-fired adsorption heat pump
<b>Netherlands</b>	NEN 5128;2004, NEN 2168;2004	Minimum energy efficiency for new buildings and large renovations (sets minimum Energy Performance Coefficient (EPC) criteria)
<b>UK</b>	BS 5410	Code of practice for oil firing. Installations up to 45 kW output capacity for space heating and hot water supply purposes
	BS 5864	Installation and maintenance of gas-fired ducted air-heaters of rated input not exceeding 70 kW
	BS 7977	Specification for safety and rational use of energy of domestic gas appliances. Radiant/convectors.
	OFS A102	Oil Firing Appliance Standard – Room heaters with Atomising or Vaporising Burners with or without Boilers, heat outputs up to 25 kW
	OFS A103	Oil Firing Appliance Standard – Used Lubricating Oil Burners for Space and Water Heating Appliances, heat outputs up to 400 kW
	Building Regulations 2010	Domestic Building Services Compliance Guide Non-domestic Building Services Compliance Guide

### Standards in EU-27

➤ Safety and Environmental Standards

Document	Type of equipment	Title
EN 378	Heat pumps	Specification for refrigerating systems and heat pumps. Safety and environmental requirements. Basic requirements, definitions, classification and selection criteria
EN/IEC 60335-1	Furnaces	Household and similar electrical appliances –Safety –
prEN16084	Heat pumps	Refrigerating systems and heat pumps. qualification of tightness of components and joints
EN 12102	Heat pumps	Air conditioners, liquid chilling packages, heat pumps and dehumidifiers with electrically driven compressors for space heating and cooling. Measurement of airborne noise. Determination of the sound power level
EN 1196	Furnaces, AHU	Domestic and non-domestic gas-fired air heaters - Supplementary requirements for condensing air heaters

## International Standards

Standard	Type of equipment	Title
ISO 5149	Heat pumps	Mechanical refrigerating systems used for cooling and heating -- Safety requirements
ISO/CD 14903	Heat pumps	Refrigerating systems and heat pumps - Qualification of tightness of components and joints
ISO 13253	Heat pumps	Ducted air-conditioners and air-to-air heat pumps - Testing and rating for performance
ISO 13256-1	Heat pumps	Water-source heat pumps -- Testing and rating for performance - Part 1: Water-to-air and brine-to-air heat pumps
ISO 23550	Furnaces	Safety and control devices for gas burners and gas-burning appliances - General requirements
ISO 23551-1	Furnaces	Safety and control devices for gas burners and gas-burning appliances – Particular requirements
ISO 23552-1	Furnaces	Safety and control devices for gas and/or oil burners and gas and/or oil appliances – Particular requirements – Part 1: Fuel/air ratio controls, electronic type
ISO 23553-1	Furnaces	Safety and control devices for gas and/or oil burners and gas and/or oil appliances – Particular requirements – Part 1: Shut-off devices for oil burners
ISO 5149	Heat pumps	Mechanical refrigerating systems used for cooling and heating -- Safety requirements
IEC 60335-2-40	Heat pumps	Household and similar electrical appliances –Safety
ISO 817	Heat pumps	Refrigerants -- Designation system

## Third Country Standards

Standard	Country	Type of equipment	Title
ANSI Z21.40.4-1996 / CGA 2.94-M9	USA / Canada	Heat pumps	Performance testing and rating of gas-fired, air conditioning and heat pump appliances
ANSI/ASHRAE 103-2007	USA	Furnaces	Method for testing Annual Fuel Utilization Efficiency (AFUE) of residential central furnaces and boilers (furnaces with input rating < 250,000 BTU/h ( $\approx$ 66 kW))
ANSI/AHRI 210/240-2008	USA	Heat pumps	Performance rating of unitary air-conditioning and air-source heat pump equipment
ANSI/AHRI 340/360-2007	USA	Heat pumps	Performance rating of commercial and industrial unitary air-conditioning and heat pump equipment
ANSI/AHRI 390-2003	USA	Heat pumps	Performance rating of single package vertical air-conditioners and heat pumps
ANSI/AHRI 870	USA	Heat pumps	Performance rating of Direct GeoExchange heat pumps
CAN/CSA-B212-00	Canada	Furnaces	Seasonal energy utilisation efficiencies of oil-fired furnaces and boilers
CAN/CSA C273.5-1980	Canada	Heat pumps	Installation requirements for air-to-air heat pumps
CAN/CSA-P.2-07	Canada	Furnaces	Testing method for measuring the annual fuel utilization efficiency of residential gas-fired furnaces (input rate < 65.9 kW (225,000 Btu/h) and boilers

## Questions

- Are there some standards which have not yet been covered in the lists provided in earlier slides?
- Do you agree with the list of test standards related to safety, environment and energy performance?
- Any comments?



### Legislation

Scope	Legislation
<b>Energy efficiency related</b>	
Entire product	Besides the Ecodesign Directive 2009/125/EC no other European legislation on energy efficiency for central heating air appliances has been identified.
System	Energy Performance of Buildings Directive (EPBD) 2010/31/EU
	Construction Products Directive 89/106/EEC
Boiler	Boiler Efficiency Directive 92/42/EEC
<b>Environmental legislation</b>	
Entire product	Ecodesign Directive 2009/125/EC
	Waste Electrical and Electronic Equipment Directive 2002/96/EC
	Restriction of the use of certain Hazardous Substances in electric and electronic equipment Directive 2002/95/EC
	Directive 89/106/EEC on the approximation of laws, regulations and administrative provisions of the Member States relating to construction products
Liquid refrigerant	Ozone depleting substances regulation 2037/2000
	Fluorinated greenhouse gases regulation 842/2006
Energy	Directive 2009/28/EC on the promotion of the use of energy from renewable sources
	Directive 2006/32/EC on energy end-use efficiency and energy services.
<b>Safety related</b>	
Entire product	Machinery Directive 2006/42/EC
	Gas Appliance Directive 90/396/EEC
	General product safety Directive 2001/95/EC
	Low Voltage equipment Directive 2006/95/EC
	Electromagnetic Compatibility Directive 2004/108/EC
	Directive 89/106/EEC on the approximation of laws, regulations and administrative provisions of the Member States relating to construction products
	Pressure Equipment Directive 97/23/EC

## Voluntary programmes

Programme	Country	Product
EU Ecolabel	EU	Heat pumps
Eurovent	EU	Air handling units
		Comfort air conditioners
		Rooftops
Nordic swan	Nordic countries	Heat pump units
		Heat pump systems
Blue angel	DE	Electric powered heat pumps
		Heat pumps gas operated
Energy Saving Recommended scheme	UK	Heating controls
Enhanced Capital Allowances	UK	Warm Air Heating Equipment (gas or oil fired)
		Heat pumps
Milieukeur programme	NL	Central heating appliances
Kwaliteitskeur warmtepompen	NL	Heat pumps for heating purposes
P-Mark	SE	Heat pumps
Promotelec	FR	Heat pumps

## Third country mandatory programmes

Programme	Country	Product
Federal Energy Conservation Standards	USA	Energy Conservation Program for Consumer Products Other than Automobiles
		Energy Efficiency Program for Certain Commercial and Industrial Equipment
Energy Guide Label	USA	Heating furnaces and heat pumps
Energy Efficiency Regulations	Canada	Gas and oil fired central furnaces and heat pumps
EnerGuide label		Gas and propane fired furnaces and air-to-air heat pumps
Gas appliance Star Rating Scheme	Australia/ New Zealand	Gas space heater

## Third country voluntary programmes

Programme	Country	Product
Energy Star Labelling Program	USA	Oil and Gas Furnaces
		Electric air-source heat pumps
Energy Star and Energuide Labelling Program	Canada	Oil and Gas Furnaces
		Electric air-source heat pumps
Top Energy Saver Award Winner	Australia/ New Zealand	Furnaces and heat pumps

## Questions

- Do you agree with this list?
- Any complementary legislation to integrate?
- Any comments?

10:00 – 10:15	Welcome, “Tour de table” (EC)
10:15 – 10:25	Introduction to the Ecodesign Directive (BIO)
10:25 – 10:40	Interaction with other Ecodesign lots (BIO)
	Task 1 - Definition: Presentation and discussion of product categories, existing standards and legislation (BIO/TÜV)
	COFFEE BREAK
	Discussion on scope and findings
13:00 – 14:00	LUNCH BREAK
	<b>Task 2 – Economic and market analysis: Presentation and discussion (BIO)</b>
	Task 3 – Consumer behaviour and local infrastructure: Presentation and discussion (BIO/TÜV)
	COFFEE BREAK
16:00 – 16:30	Next steps – Tasks 4, 5 and 6 (BIO)
	Discussion on base cases (BIO/TÜV)
16:30 – 17:00	Conclusion and wrap up (EC)

## Task 2 – Economic & market analysis:

- Place the product group within the total of EU industry and trade policy
- Provide market and cost inputs for the EU-wide environmental impact of the product group
- Provide insight in the latest market trends
- Provide a practical dataset of prices and rates to be used in a Life Cycle Cost (LCC) calculation

2.1 Generic economic data

2.2 Market and stock data

2.3 Market trends

2.4 Consumer expenditure base data

## Prodcom data (in 1,000 units, 2009)

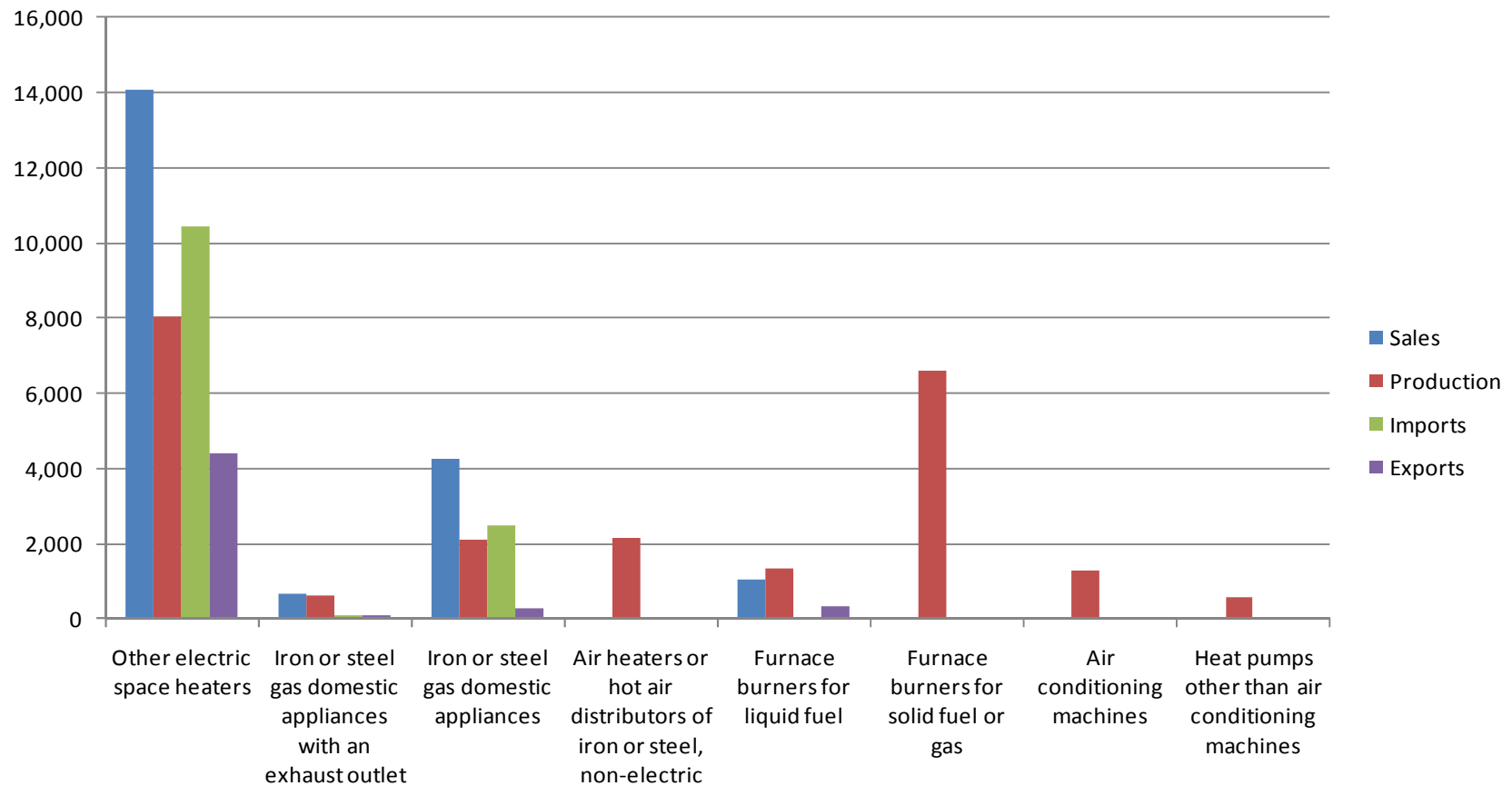

## Prodcom data (value in million euros, 2009)

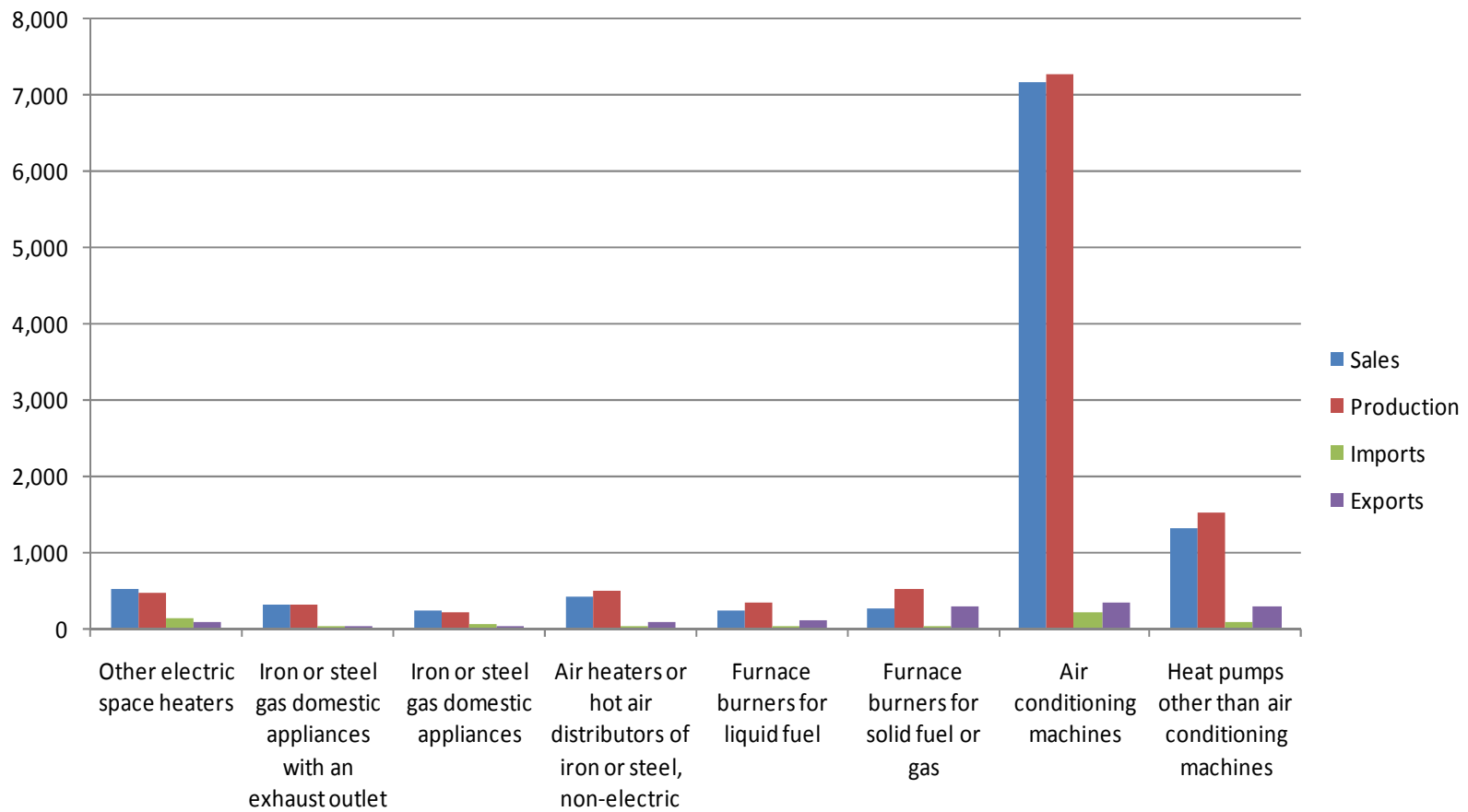

## Air-based central heating appliances in EU

Sector	Estimated share of units sold (%)	Source
Residential	2%	Industry
Commercial	42%	Industry
Industrial	42%	Industry
Agricultural	14%	Industry

## Sales of central heating furnaces (EU, 2008)

Furnace type	Sales [units]	Data source
Direct-gas-fired furnaces		
Indirect-gas-fired furnaces	833,333	Estimate based on one manufacturer
Liquid-fuel-fired furnaces		
Electric furnaces		
Multi-fuel-fired furnaces (wood/coal and fuel oil)		
<b>Total Furnaces</b>	5,000,000	Estimate

## Central heating furnaces per capacity range

Type of furnace	Division by capacity range in kW [%]				
	4-19 kW	19-65 kW	65-120 kW	120-400 kW	>400 kW
Direct-gas-fired furnaces	0%	0%	30%	40%	30%
Indirect-gas-fired furnaces	0%	15%	20%	40%	25%
Liquid-fuel-fired furnaces	0%	15%	20%	40%	25%
Electric furnaces					
Multi-fuel-fired furnaces (wood/coal and fuel oil)	5%	20%	40%	35%	0%

### Installed stock of central heating furnaces

Type of furnace	Installed stock [units]	Share (%)	Data source
Direct-gas-fired furnace			
Indirect-gas-fired furnace (residential only)	666,667		Industry
Indirect-gas-fired furnace (commercial and industrial)			
Liquid fuel-fired furnace			
Electric furnace			
Multi-fuel-fired furnaces (wood/coal and fuel oil)			
<b>Total furnaces</b>			

### Heat pump sales (EU, 2008)

Total heat pump sales (EU, 2008) Source: EHPA 2009

Type of heat pump	Sales (units)	Market share
Reversible air-air	210,000	35%
Ground Source Heat Pump	120,000	20%
Exhaust air	24,000	4%
Tap water	30,000	5%
Air-Water	216,000	36%
<b>Total EU 2008</b>	<b>600,000</b>	<b>100%</b>

Heat pump sales >12 kW (EU, 2008)

Type of application	Sales [units]	Market share (%)	Data source
Air-to-air	417,500	95%	Industry
Water-to-air	10,987	2.5%	Estimate
Ground-to-air	10,987	2.5%	Estimate
<b>Total heat pumps</b>	<b>439,474</b>	<b>100%</b>	<b>Estimate</b>

### Heat pump sales (Italy, 2008)

Product	Sales in Italy 2008 (units)	Source
VRF heat pumps	15,160	Industry
Heat pumps with inverter system	671,521	Industry
Rooftop heat pumps	1,787	Industry
<i>Total heat pumps</i>	<i>1,222,834</i>	Industry
Total split system	1,251,159	Industry

### VRF heat pump sales in EU

JARN

Country	VRF sales (2006)
UK	13,000
France	11,000
Italy	10,000
Spain	9,000
Germany	5,000
<b>Total</b>	<b>64,000</b>

### Heat pump sales in EU

EHPA 2008

Member State	Sales 2006 [Units]	Sales 2007 [Units]
Austria	8,853	14,662
Finland	36,950	46,150
France	53,510	69,600
Germany	51,827	52,630
Italy	21,665	28,901
Sweden	122,473	93,791
<b>Total</b>	<b>295,278</b>	<b>305,734</b>

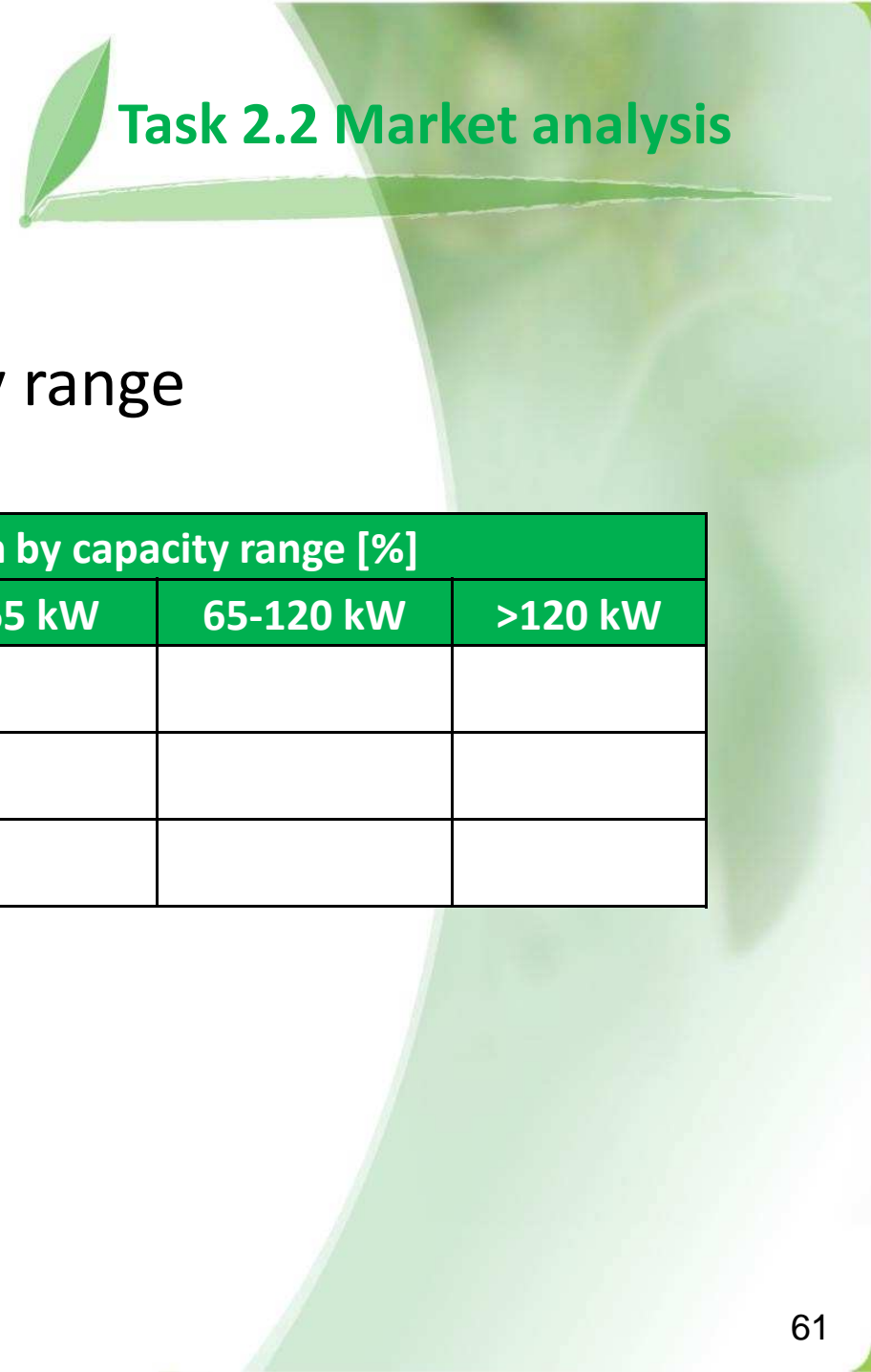

### Heat pump sales per capacity range

Type of application	Division by capacity range [%]			
	4-19 kW	19-65 kW	65-120 kW	>120 kW
Air-to-air				
Water-to-air				
Ground-to-air				

### Installed stock of heat pumps

Type	Installed stock [units]	Share (%)	Data source
Air-to-air	3,072,500	95%	Industry
Water-to-air	80,855	2.5%	Industry
Ground-to-air	80,855	2.5%	Industry
<b>Total heat pumps</b>	<b>3,234,211</b>	<b>100%</b>	<b>Industry</b>

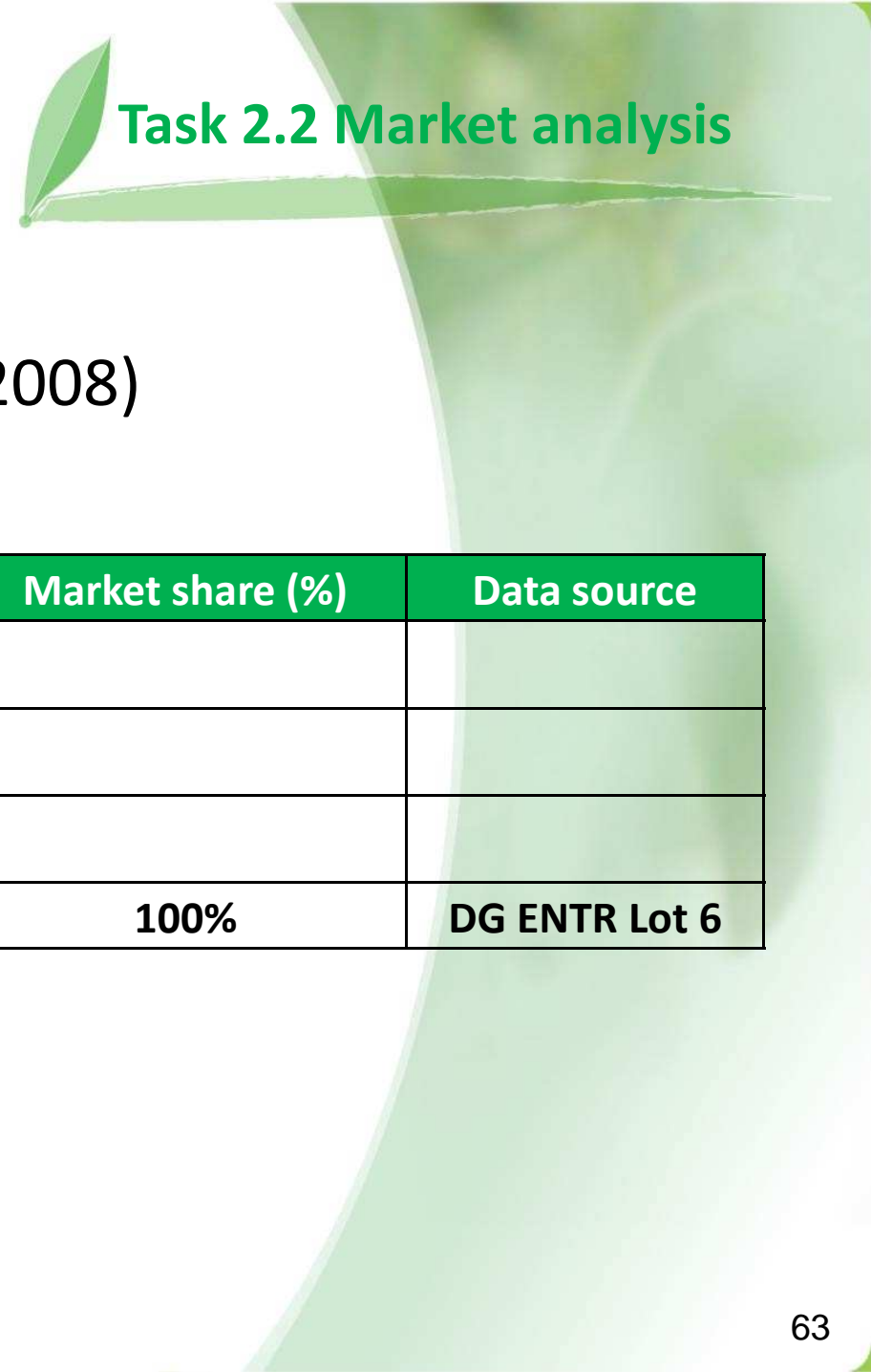

### Air handling units sales (EU, 2008)

Type of application	Sales [units]	Market share (%)	Data source
Gas-fired			
Oil-fired			
Electric AHU			
<b>Total air handling units</b>	<b>205,874</b>	<b>100%</b>	<b>DG ENTR Lot 6</b>

## Air handling units sales (Italy, 2008)

Product type	Sales (units)	Source
Packaged AHUs (or very big ducted fan coil units)	4,432	Industry
AHUs up to 20,000 m <sup>3</sup> /h	5,400	Industry
AHUs from 21000 up to 50,000 m <sup>3</sup> /h	1,391	Industry
AHUs above 51,000 m <sup>3</sup> /h	256	Industry
<b>TOTAL</b>	<b>11,479</b>	Industry

### Air handling units per capacity range and application

Type of application	Division by capacity range [%]			
	4-19 kW	19-65 kW	65-400 kW	> 400 kW
Gas-fired	0%	35%	60%	5%
Oil-fired	0%	35%	60%	5%
Electric AHU				

AHU characteristic	% share of overall AHU market in EU
Heating only	17%
Cooling only	13%
Heating and Cooling	65%
Neither cooling nor heating (ventilation)	18%

### Installed stock of air handling units

Type	Installed stock [units]	Share (%)	Data source
Gas-fired			
Oil-fired			
Electric AHU			
<b>Total air handling units</b>	<b>3,100,000</b>	<b>100%</b>	<b>DG ENTR Lot 6</b>

## Fan coil sales (Italy, 2008)

Type of Fan coil unit	Sales (units)	Source
Console type fan coils with cabinet	337,161	Industry
Console type fan coils without cabinet (concealed type)	81,657	Industry
Cassette type fan coils	52,315	Industry
Hi-Wall type Fan coils	26,483	Industry
<b>TOTAL</b>	<b>497,616</b>	Industry

# Distribution channels

**Distribution chain for furnaces**  
(all fuel types for residential, commercial and industrial applications)

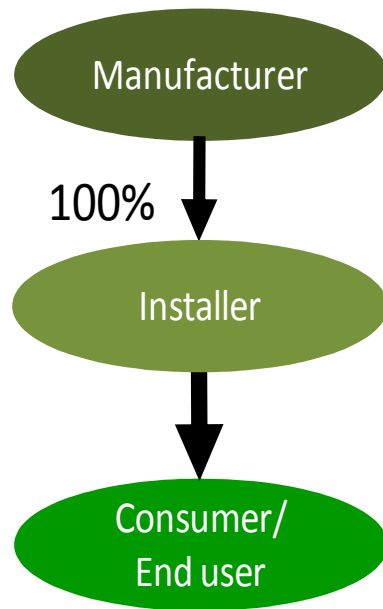

**Distribution chain for heat pumps**  
(all fuel types for residential, commercial and industrial applications)

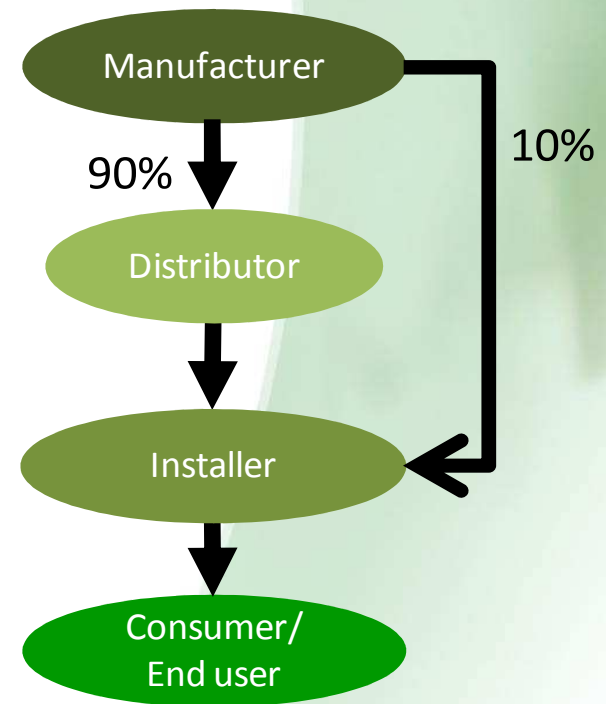

## Distribution channels

Distribution chain for AHU (all fuel types and for both commercial and industrial applications)

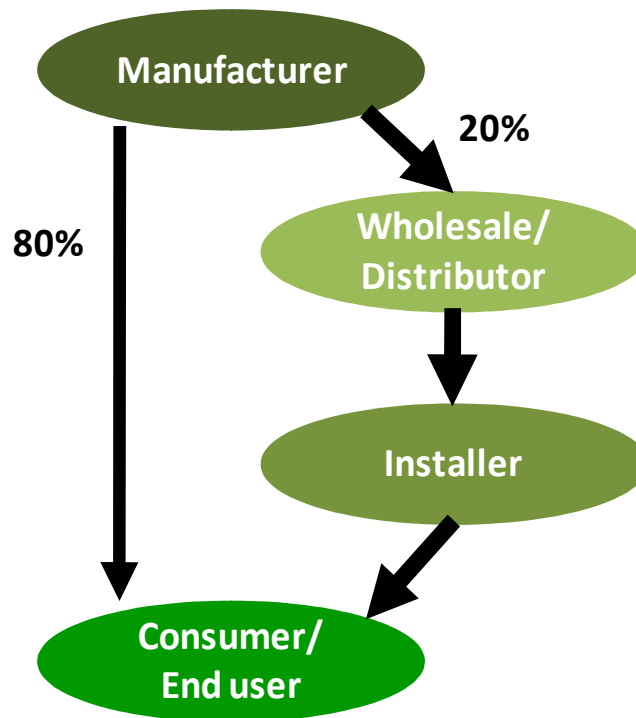

## EU sales trends

	Product	Trend 2010-2015 (%)	Trend 2015-2025 (%)
Furnaces	Direct-gas-fired furnace		
	Indirect-gas-fired furnace (residential only)	-5%	
	Indirect-gas-fired furnace (commercial and industrial)		
	Liquid fuel-fired furnace		
	Electric furnace		
	Multi-fuel-fired furnaces (wood/coal and fuel oil)		
Heat pumps	Air-to-air heat pumps	+2% to +5%	+2% to +5%
	Water-to-air heat pumps		
	Ground-to-air heat pumps		
Air handling units		+3%	

### Consumer expenditure for furnaces

	Direct-gas-fired	Indirect-gas-fired	Liquid fuel-fired	Electric	Multi fuel-fired
Average power capacity (in kW)	100-300 kW	20-120 kW	100-300 kW		
European product price range (in €/kW)	35-120 €/kW	80 €/kW	25-100 €/kW		
Average European product price per unit (in €)	€ 4 000		€ 3 800		
Installation cost (€)	€ 11,000 – 12,500	€ 16,000 – 20,000			
Maintenance and repair cost (€/year)		€ 1,100			
Disposal cost (€)		€ 100			

### Consumer expenditure for heat pumps

	Air-to-air	Water-to-air	Ground-to-air
Average power capacity (in kW)	35 kW	35 kW	35 kW
European product price range (in €/kW)	430 €/kW*		830 -1,600 €/kW
Average European product price (in €)	€ 15,200		
Installation cost (€)	€ 5,300		
Maintenance and repair cost (€/year)	€ 1,800		
Disposal cost (€)			
*European single-family dwelling product price range (IEA, 2011) is from 392 €/kW to 1,000 €/kW			

## Consumer expenditure for air handling units

	Gas	Oil	Electricity
Average power capacity (in kW)	200-300 kW	200-300 kW	65 kW
European product price range (in €/kW)		50-150 €/kW	
Average European product price (in €)		€ 17 500	
Installation cost (€)			
Maintenance and repair cost (€/year)			
Disposal cost (€)			



## Task 2

### Questions

- Inputs on sales
- Inputs on stocks
- Inputs on prices
- Inputs on market trends
- Any comments?

10:00 – 10:15	Welcome, “Tour de table” (EC)
10:15 – 10:25	Introduction to the Ecodesign Directive (BIO)
10:25 – 10:40	Interaction with other Ecodesign lots (BIO)
	Task 1 - Definition: Presentation and discussion of product categories, existing standards and legislation (BIO/TÜV)
	COFFEE BREAK
	Discussion on scope and findings
13:00 – 14:00	LUNCH BREAK
	Task 2 – Economic and market analysis: Presentation and discussion (BIO)
	<b>Task 3 – Consumer behaviour and local infrastructure: Presentation and discussion (BIO/TÜV)</b>
	COFFEE BREAK
16:00 – 16:30	Next steps – Tasks 4, 5 and 6 (BIO)
	Discussion on base cases (BIO/TÜV)
16:30 – 17:00	Conclusion and wrap up (EC)

## Task 3 – Consumer Behaviour and Local Infrastructure:

- Quantify relevant user-parameters that influence the environmental impact during product-life and that are different from Standard test conditions
- Identify barriers and restrictions to possible eco-design measures, due to social, cultural or infra-structural factors

3.1 Real life efficiency

3.2 End-of-life behaviour

3.3 Local infra-structure

## Purchase decisions

Reason for installing new central heating

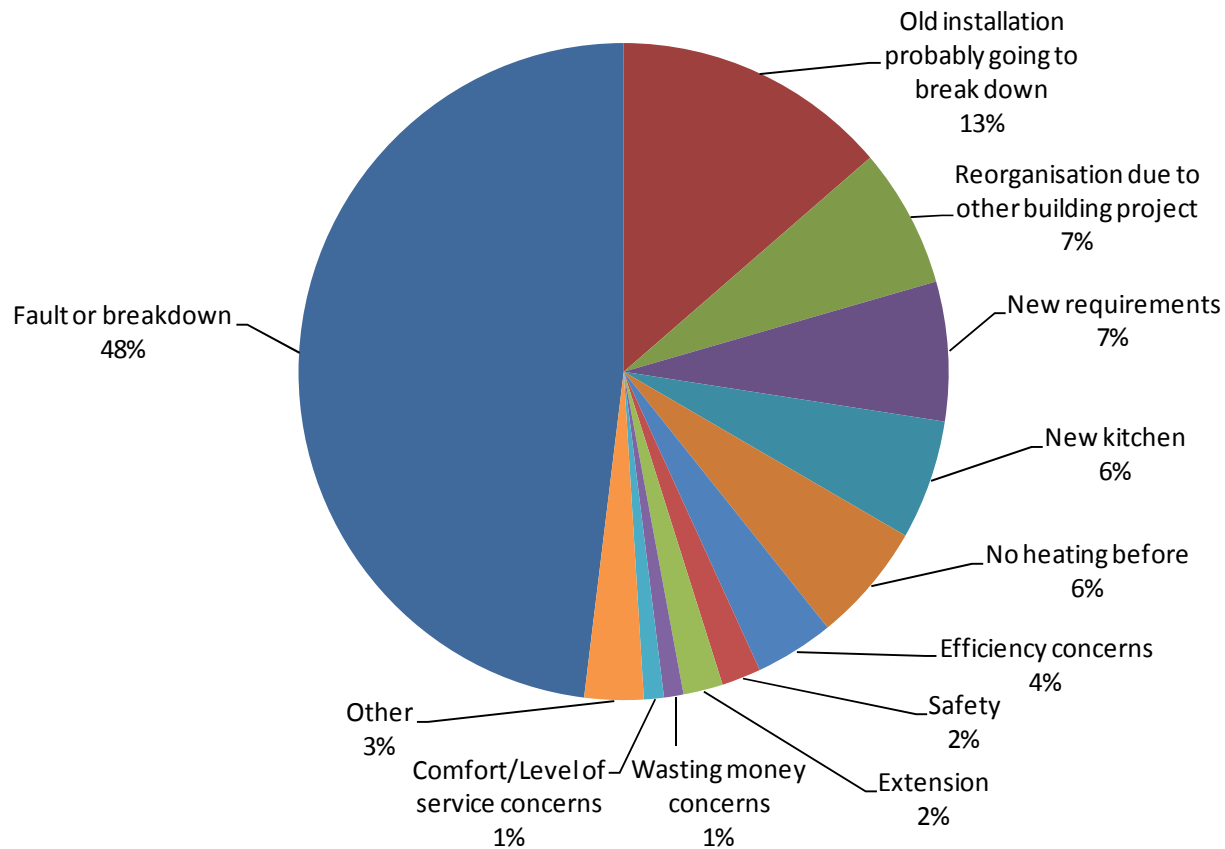

## Decision chain

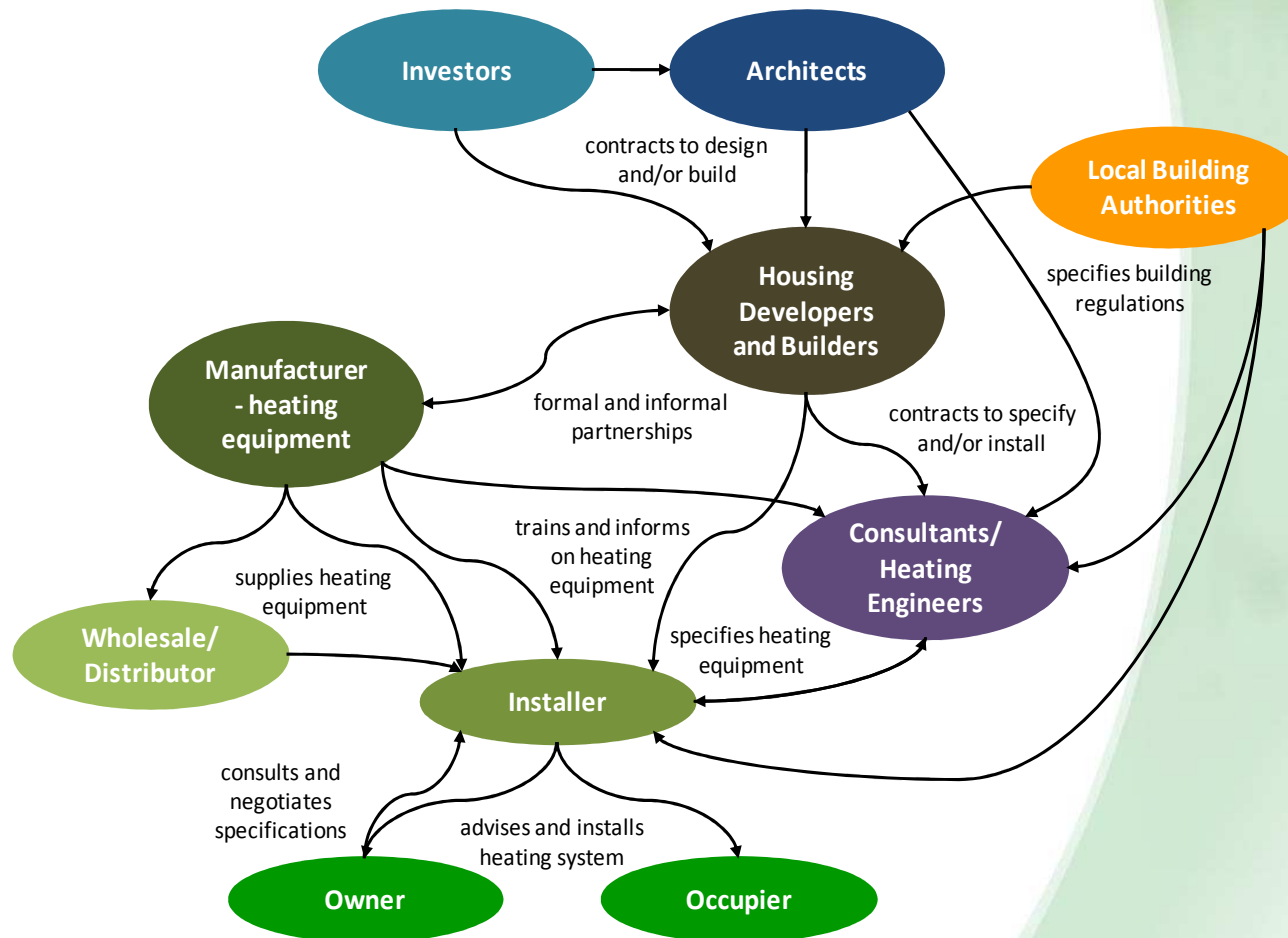

## Use pattern

Product		Average working hours per year (heating mode)	
		Residential	Non-residential
Furnaces	Direct-gas-fired furnaces		
	Indirect-gas-fired furnaces		
	Liquid-fuel-fired furnaces		
	Electric furnaces		
	Multi-fuel-fired furnaces (wood/coal and fuel oil)		
Heat pumps	Air-to-air		
	Water-to-air		
	Ground-to-air		
Air handling units	Gas-fired		
	Oil-fired		
	Electric AHU		

## Product economic and technical life

Type of appliance	Heat generation source	Average product life (in years)	
		Economic life	Technical life
Furnace	Direct- gas- fired	10	15
	Indirect-gas -fired	15	20
	Liquid-fuel-fired	10	20
	Electric	10	20
	Multi-fuel-fired	10	20
Heat pump	Air-to-air	15	20
	Water-to-air	15	20
	Ground-to-air	15	20
AHU	Gas	20	30
	Oil	20	30
	Electricity	20	30

## End of life practices

- Products almost 100% recyclable
- Take-back services by installers/manufacturers
- Rarely reused in second-hand market
- Household appliances affected by WEEE Directive

## Questions

- Inputs on average working hours
- Agree with product lifetimes?
- Inputs on End of Life practices
- Any comments?

10:00 – 10:15	Welcome, “Tour de table” (EC)
10:15 – 10:25	Introduction to the Ecodesign Directive (BIO)
10:25 – 10:40	Interaction with other Ecodesign lots (BIO)
	Task 1 - Definition: Presentation and discussion of product categories, existing standards and legislation (BIO/TÜV)
	COFFEE BREAK
	Discussion on scope and findings
13:00 – 14:00	LUNCH BREAK
	Task 2 – Economic and market analysis: Presentation and discussion (BIO)
	Task 3 – Consumer behaviour and local infrastructure: Presentation and discussion (BIO/TÜV)
	COFFEE BREAK
<b>16:00 – 16:30</b>	<b>Next steps – Tasks 4, 5 and 6 (BIO)</b>
	Discussion on base cases (BIO/TÜV)
16:30 – 17:00	Conclusion and wrap up (EC)

## Task 4 – Technical Analysis Existing Products:

- General technical analysis of current products on the EU market during the whole life cycle
- Objective is to capture the market on the whole, both “good” and “bad” products
- Functional analysis of the system to which the product belongs (e.g. heating/ventilation), including a rough estimate of the overall impacts

4.1 Production phase

4.2 Distribution phase

4.3 Use phase (product)

4.4 Use phase (system)

4.5 End-of-life phase

4.6 Recommendations on mandates for measurement standards

## Task 5 – Base-Cases:

- Building on the results of Tasks 1 – 4, “one or two average EU product(s)” or product category(ies) have to be defined as the “Base-case” for the whole of the EU-27
- On these Base-Cases most of the environmental and Life Cycle Cost analyses will be built throughout the rest of the study
- The Base-Case is a conscious abstraction of reality

(5.0 Base case definition)

5.1 Product-specific inputs

5.2 Base-Case Environmental Impact Assessment

5.3 Base-Case Life Cycle Costs

5.4 EU Totals

## Task 6 – Technical Analysis BAT:

- Technical analysis of advanced technologies (“BAT candidates”)
- Provides part of the input for Task 7 (identification of BAT)

- 6.1 State of the art in applied research for the product: **BAT** (*prototype level*)
- 6.2 State of the art at component level: **BNAT** (*prototype, test and field trial level*)
- 6.3 State of the art of best existing product technology outside the EU: **BAT**

Some clippings about the energy savings claims:

- Hi-Efficiency, reduce operating costs up to 50%



**HEAT PUMP CONVECTOR - MUCH MORE THAN A FAN COIL UNIT**

> Approximately 25% efficiency improvement compared to a heating system combining under floor heating and regular fan coil units

- Reduced running costs – savings of up to 60% can be achieved

# Timeline

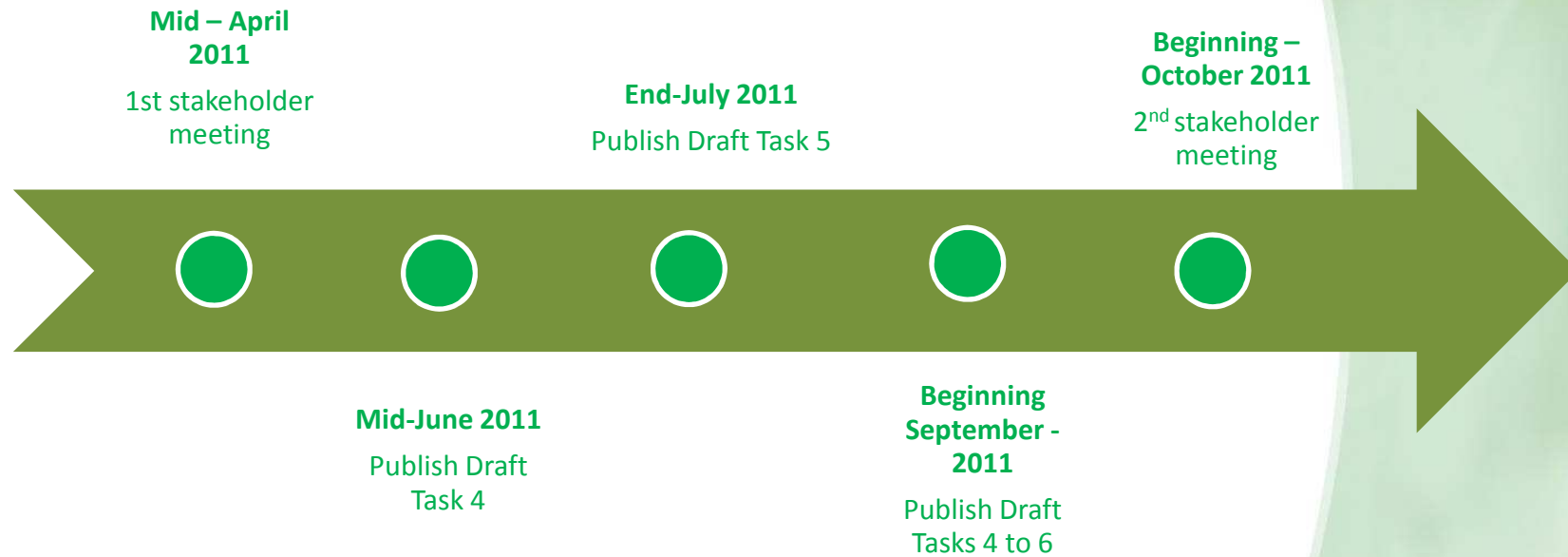

Benefitting from energy efficiency calculation models for heating systems already available from literature:

- EuP studies
  - Revised version of model used in ENER Lot 1 study
  - Model used in ENTR Lot 6 study
- EPBD
  - Methodology proposed in DIN V 18599 standard
  - Methodology proposed in EN 15316 standard

- Following data requirements for Environmental Impact Assessment and Life Cycle Cost Calculations:
  - Bill Of Materials (BOM)
  - Resource (energy) consumption
  - Other consumptions (refrigerant...)
  - End-of-Life scenarios (recycling data)
  
- We will send questionnaire to stakeholders to collect this information

10:00 – 10:15	Welcome, “Tour de table” (EC)
10:15 – 10:25	Introduction to the Ecodesign Directive (BIO)
10:25 – 10:40	Interaction with other Ecodesign lots (BIO)
	Task 1 - Definition: Presentation and discussion of product categories, existing standards and legislation (BIO/TÜV)
	COFFEE BREAK
	Discussion on scope and findings
13:00 – 14:00	LUNCH BREAK
	Task 2 – Economic and market analysis: Presentation and discussion (BIO)
	Task 3 – Consumer behaviour and local infrastructure: Presentation and discussion (BIO/TÜV)
	COFFEE BREAK
16:00 – 16:30	Next steps – Tasks 4, 5 and 6 (BIO)
	<b>Discussion on base cases (BIO/TÜV)</b>
16:30 – 17:00	Conclusion and wrap up (EC)



## Potential base cases

- Assessment of average EU products, the so called “**base cases**”
  - A base case is “a conscious abstraction of reality”
- The description of the Base Cases is the synthesis of the results of Tasks 1 to 4
- Most of the environmental and life cycle cost analysis are built on these Base Cases throughout the rest of the study and it serves as the point-of-reference for Task 6 (technical analysis of BAT), Task 7 (improvement potential), and Task 8 (policy analyses)

## Base case selection

- A different base case for major product categories sold on the market is the main driving factor for selecting base cases
- The base cases selected must best represent the broadest categories of the ENER Lot 21 scope.
- Technical differences can justify the distinction of a new base case such as significant differences in functionality, fuel used for heat generation, market niche, or energy savings potential



## Base cases



To calculate the total environmental impacts of all heating products in EU an LCA needs to be performed on each product and then multiplied by the stock volume.

## Base cases



Instead of calculating the total environmental impacts of all heating products in EU, the environmental impacts of a limited number of 'characteristic' average EU heating products are assessed and then multiplied by the estimated aggregated sales volume.

## Proposed Distinction

- **Residential vs non-residential:** pattern of use and differences in type of heaters
- **Fuel type: gas – electricity – liquid fuel:** differences between local fuel infrastructures in EU
- **Annual sales volume** in EU-27
- **Installed stock** in EU-27
- **Energy savings potential** at the EU-27 level

## Potential base cases

### ➤ Furnaces

1. Indirect-gas-fired furnace (residential and non-residential)
2. Electric furnace (residential and non-residential)
3. Liquid fuel-fired furnace (residential and non-residential)

### ➤ Heat pumps

1. Air-to-air electric heat pump

### ➤ Air handling units

1. Electric Air handling unit



## Potential base cases

### Questions

- Agree with the base cases?
- Are they representative of the EU market?
- Any comments?

10:00 – 10:15	Welcome, “Tour de table” (EC)
10:15 – 10:25	Introduction to the Ecodesign Directive (BIO)
10:25 – 10:40	Interaction with other Ecodesign lots (BIO)
	Task 1 - Definition: Presentation and discussion of product categories, existing standards and legislation (BIO/TÜV)
	COFFEE BREAK
	Discussion on scope and findings
13:00 – 14:00	LUNCH BREAK
	Task 2 – Economic and market analysis: Presentation and discussion (BIO)
	Task 3 – Consumer behaviour and local infrastructure: Presentation and discussion (BIO/TÜV)
	COFFEE BREAK
16:00 – 16:30	Next steps – Tasks 4, 5 and 6 (BIO)
	Discussion on base cases (BIO/TÜV)
16:30 – 17:00	Conclusion and wrap up (EC)



**Any other questions/comments?**

**Thank you for your participation!**

**[www.ecoheater.org](http://www.ecoheater.org)**

**BIO Intelligence Service**

Shailendra Mudgal ([shailendra.mudgal@biois.com](mailto:shailendra.mudgal@biois.com))

Adrian Tan ([adrian.tan@biois.com](mailto:adrian.tan@biois.com))

Alvaro de Prado Trigo ([alvaro.deprado@biois.com](mailto:alvaro.deprado@biois.com))

*Tel: +33 1 53 90 11 80*